

This document provides a brief overview of the project.

For further information or access to the source code, please feel free to contact me.

Introduction

- Modern CPUs require I/O mechanisms
- TinyRISC was previously a minimal CPU without terminal or output functionality
- Focus: Combine hardware (SystemC) and software (assembler)

Initial Implementation of TinyRisc

- Basic assembler with limited instruction support
- Simple instruction execution (add, ld, etc.)
- Functional 5-stage CPU pipeline

Final Implementation of TinyRisc

- jal & label support
- Terminal module for output
- Framework integration
- Linker for multi-file programs
- stdio.S library with print function

Overview of the Initial TinyRISC Design

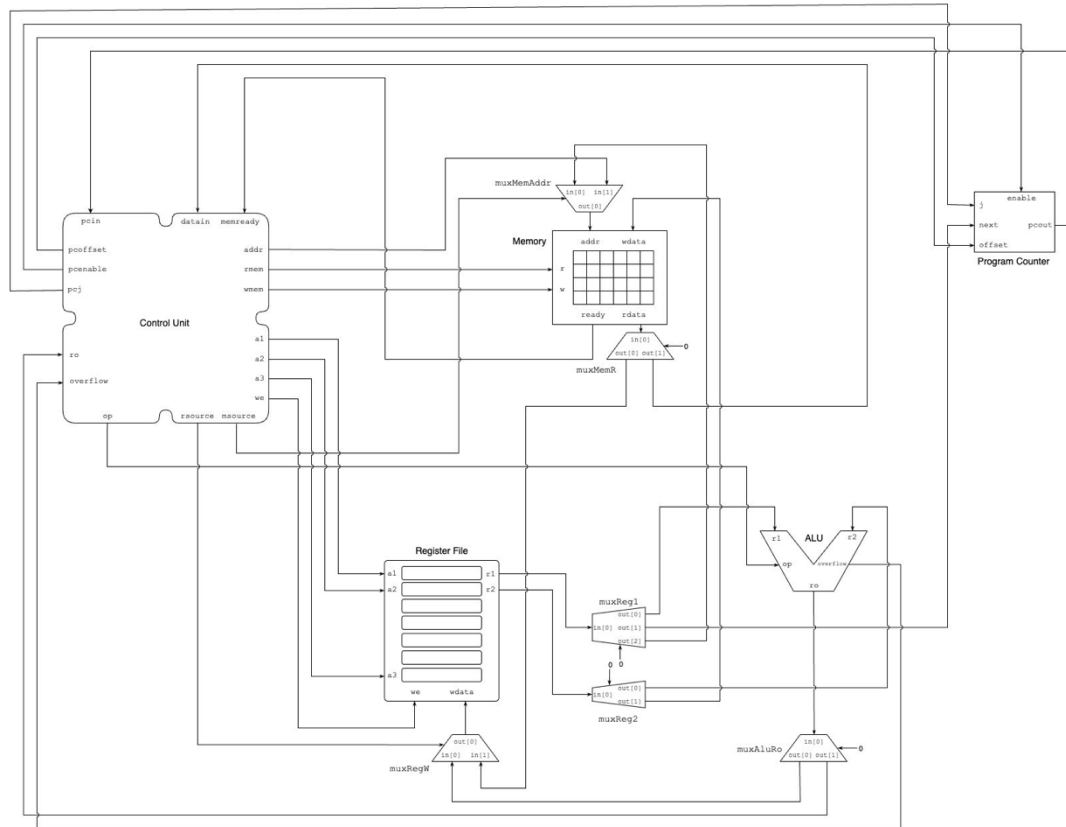

Overview of the Final TinyRISC Design

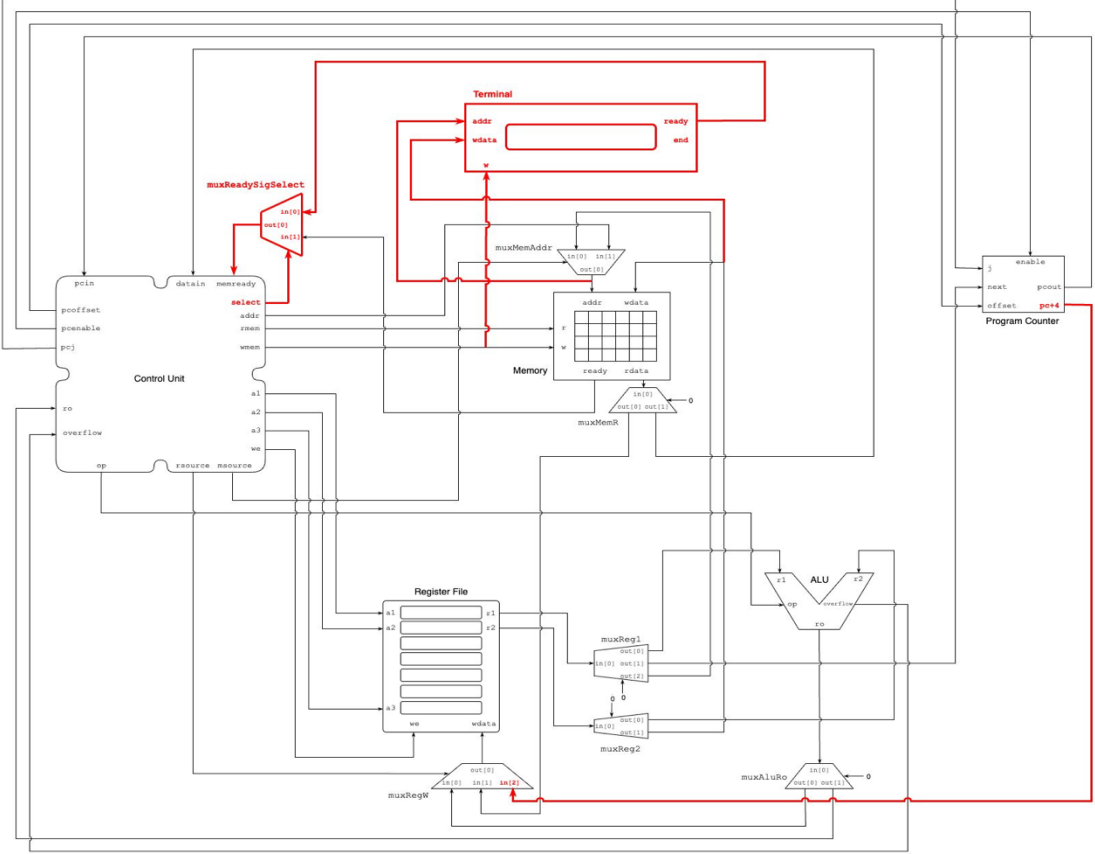

Implementation

- The JAL instruction was added by updating the assembler and the TinyRISC CPU (CU and PC)

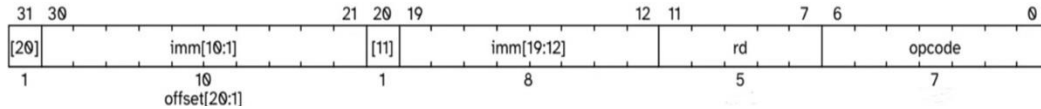

The RISC-V Instruction Set Manual Volume I | © RISC-V International

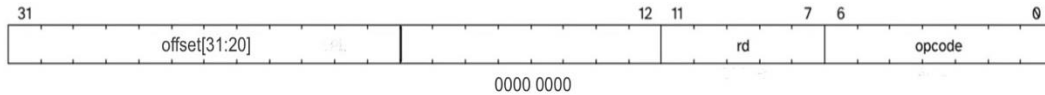

TinyAssembler

```
jal x31, hello_world

hello_world: # This function doubles the value in x9.
    add x9, x9, x9
    j x31 # return to address before function call.
```

Implementation

- Labels: The assembler gives the label the value contained in the assembler's current location counter [x]

- Switched to two-pass assembler
- Storing labels in hashmap

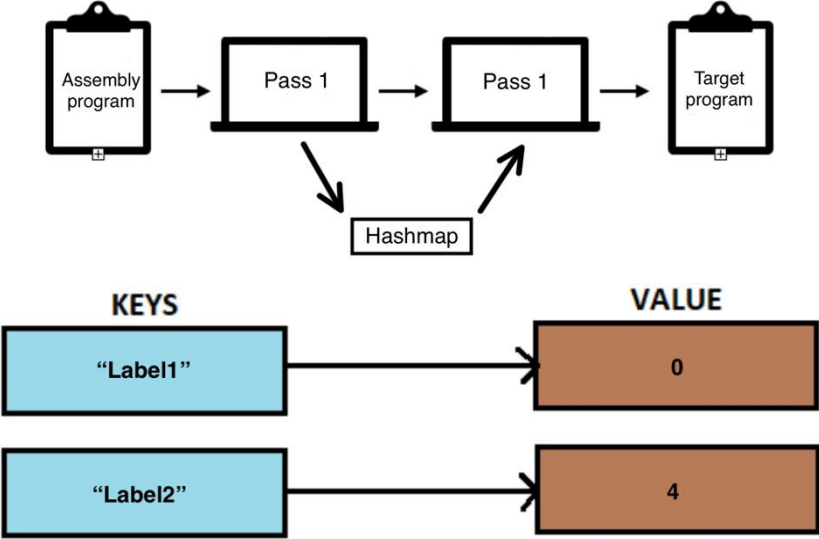

Implementation

- Linker: combines the input file with multiple libraries
- stdio.S: contains assembly functions
 - Printing Function (print);
 - Greatest Common Divisor (gcd);
 - Extra function (printProject);

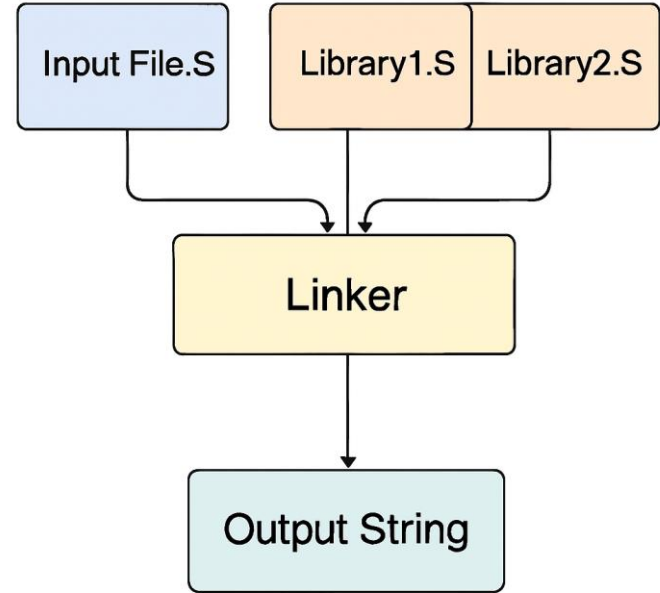

Summary & Prospects

- Supporting jal lays the foundation for adding more instructions
- Developed a minimal RISC-V system, ready for further expansion
- Added a basic include feature, enabling future assembler extensions
- Gained deeper insight into C, C++, RISC-V, and SystemC

Sources

- <https://github.com/riscv/riscv-isa-manual/>
- <https://troydhanson.github.io/uthash/>
- <https://www.ibm.com/docs/en/aix/7.2.0?topic=statements-labels>
- <https://www.youtube.com/watch?v=di5WodGWTiY>
- <https://www.geeksforgeeks.org/software-engineering/linker/>